

LED Tri-proof Batten Light with Sensor | 24W



Motion+daylight sensor
Detection area: 4-6 m
Hold on time :30s/1min/10min/30min
With remote control

Shenzhen ERS Technology

Factory Add: C209, Baohuasen International Center, Qianjin Second Road, Xixiang Town, Bao'an District, Shenzhen, China
Warehouse Add: 25 Meriton Place, Clayton South, VIC 3169

Tel: 0401 826 618

Email: info@erstech.com.au



IPART
Independent Pricing and Regulatory Tribunal
New South Wales



Victorian
Energy
Upgrades



LM-80 TM21 LM79
ISTMT LCP



APPLICATION

Indoor and outdoor lighting, with IP65, it can be used at chick en farm, basement, car parking, warehouses, corridors, outside of building, etc



SPECIFICATIONS

Item Code	ERS-TRI24WS
Product Size (mm)	1207X91X78
Power	24W
Sensor	Daylight&Microwave Motion Sensor,Sensing distance 4-6M
Input Voltage	AC220~240V,50Hz
Opal Diffuser Material	PC
Body Mateial	PC
Body Colour	Grey
Clips	stainless steel clips
Driver Brand	PHILIPS Element non-isolated driver 3 years warranty
Efficiency	150lm/w
LED Type	SMD 2835
CCT	3000K,4000K,5000K,6500K
CRI	Ra > 80
Power Factor	> 0.9
Beam Angle	120°
IP Rating	IP65
Warranty	3 years
VEET	Approved
IPART	Approved

Shenzhen ERS Technology

Factory Add: C209, Baohuasen International Center, Qianjin Second Road, Xixiang Town, Bao'an District, Shenzhen, China
Warehouse Add: 25 Meriton Place, Clayton South, VIC 3169

Tel: 0401 826 618

Email: info@erstech.com.au



LM-80 TM21 LM79
ISTMT LCP



LED MANUAL INSTRUCTION

Safety Notice:

- ❶ Installation should be done by registered electricians.
- ❷ Before replacing the driver, please switch off the power supply and wait until it cools down completely.
- ❸ Never touch the working luminaire
- ❹ In any case of malfunction, switch off the power supply immediately, and do not try to repair it yourself.
- ❺ Repairment should only be done by registered electricians or official service agent.

Include

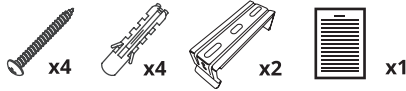

Not Include

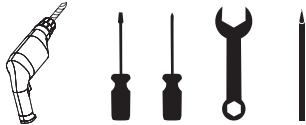

Model	Power	Fixing Hole Centre
ERS-TRI12WS	12W	280mm
ERS-TRI24WS	24W	770mm
ERS-TRI36WS	36W	770mm

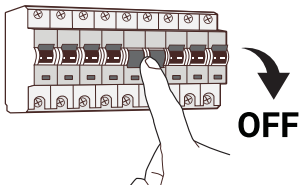

WARNING

Switch off the power supply before installation



1. Drill a $\varnothing 6\text{mm}$ hole

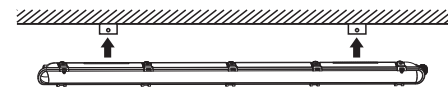

3. Fix the luminaire with the brackets

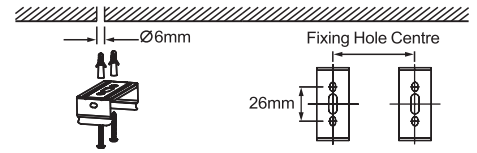

2. According to the Fixing hole centre, instal expansion bolts and screws, instal the bracket.



4. Finish installation

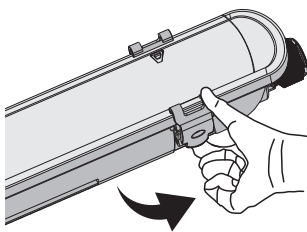

1. Unbuckle the clips

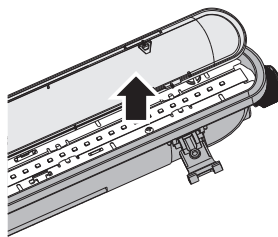

2. Take out of the diffuser

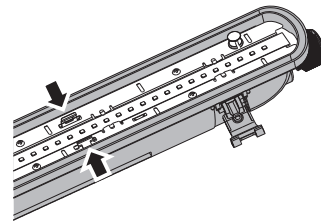

3. Push down the U brackets

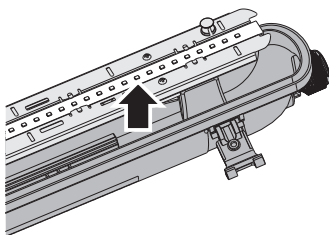

4. Take out of the LED module

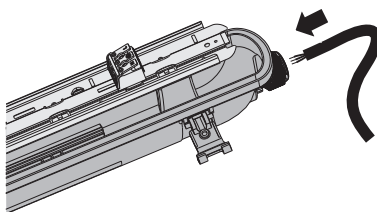

5. Insert the cable through the cable gland

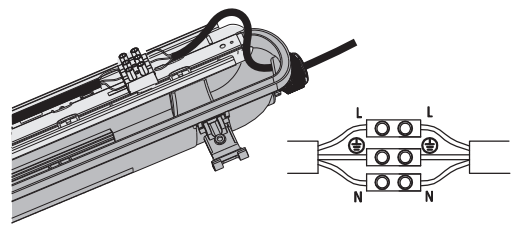

6. Connect the wires, L to L, N to N, \ominus to \ominus

Shenzhen ERS Technology

Factory Add: C209, Baohuasen International Center, Qianjin Second Road, Xixiang Town, Bao'an District, Shenzhen, China
Warehouse Add: 25 Meriton Place, Clayton South, VIC 3169

Tel: 0401 826 618

Email: info@erstech.com.au



IPART
Independent Pricing and Regulatory Tribunal
New South Wales



Victorian Energy Upgrades



LM-80 TM21 LM79
ISTMT LCP

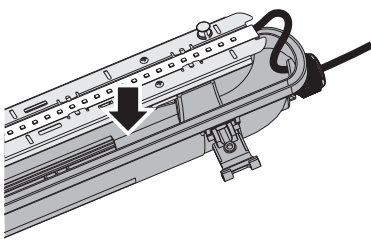

7. Put back the LED module

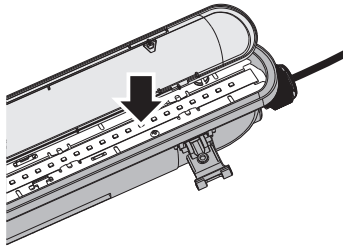

8. Close the luminaire

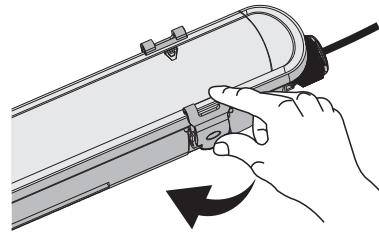

9. Buckle the clips



WARNING

Switch off the power supply before installation

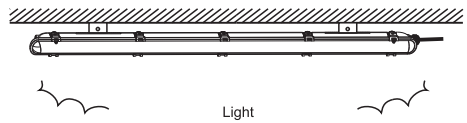

Light

PACKING

N.W.(KG)	G.W.(KG)	CARTON SIZE(mm)	QTN/CTN
12.6	14.6	1225X290X260	9

Package size (1200mm item)

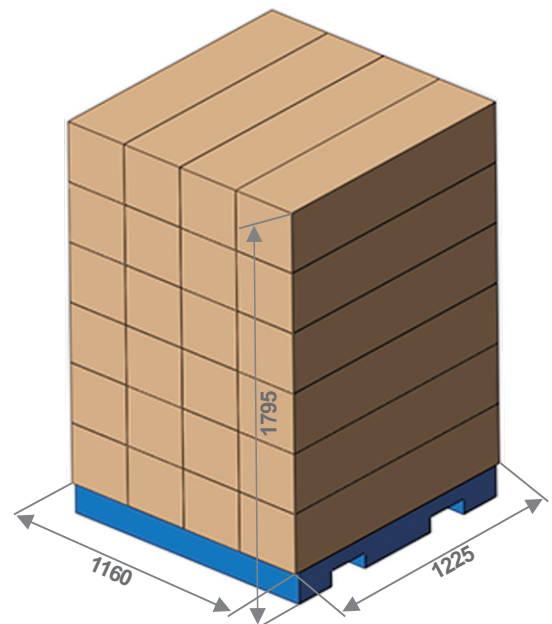
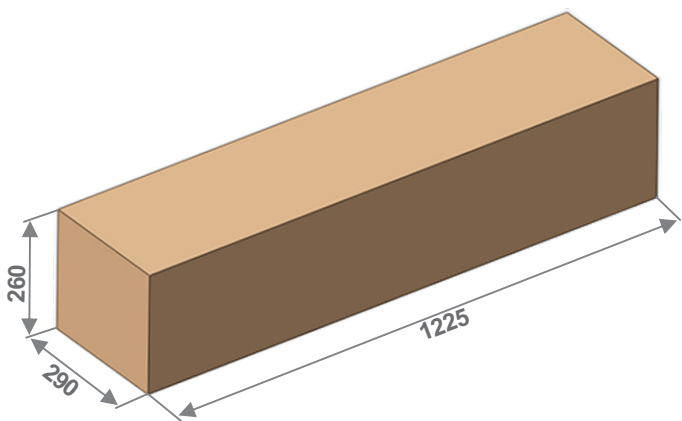

Shenzhen ERS Technology

Factory Add: C209, Baohuasen International Center, Qianjin Second Road, Xixiang Town, Bao'an District, Shenzhen, China
Warehouse Add: 25 Meriton Place, Clayton South, VIC 3169

Tel: 0401 826 618

Email: info@erstech.com.au



IPART
Independent Pricing and Regulatory Tribunal
New South Wales



3 year warranty

LM-80 TM21 LM79
ISTMT LCP



DETAILS



ON/OFF: On/off lamp (sensor stops working when lamp off)

Auto Mode: when lamp is on, press to open sensor; sensor mode goes back to the setting of last time.

- Test: 3s, 0%
- Reset: back to default setting data (5s, 0%, daylight sensor disable)
- Detection range
- Hold on time
- Daylight threshold

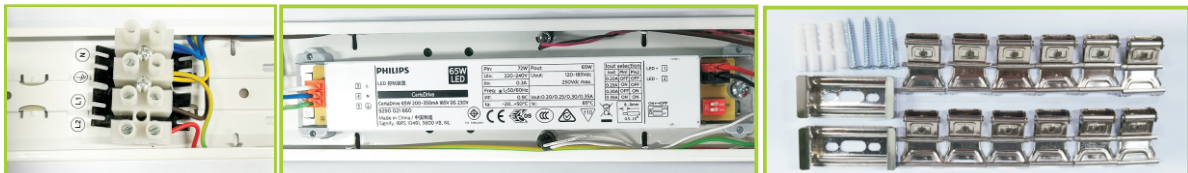

Shenzhen ERS Technology

Factory Add: C209, Baohuasen International Center, Qianjin Second Road, Xixiang Town, Bao'an District, Shenzhen, China
 Warehouse Add: 25 Meriton Place, Clayton South, VIC 3169

Tel: 0401 826 618

Email: info@erstech.com.au



IPART
Independent Pricing and Regulatory Tribunal
New South Wales



LM-80 TM21 LM79
ISTMT LCP

